

FURUNO

AIS
Automatic Identification System

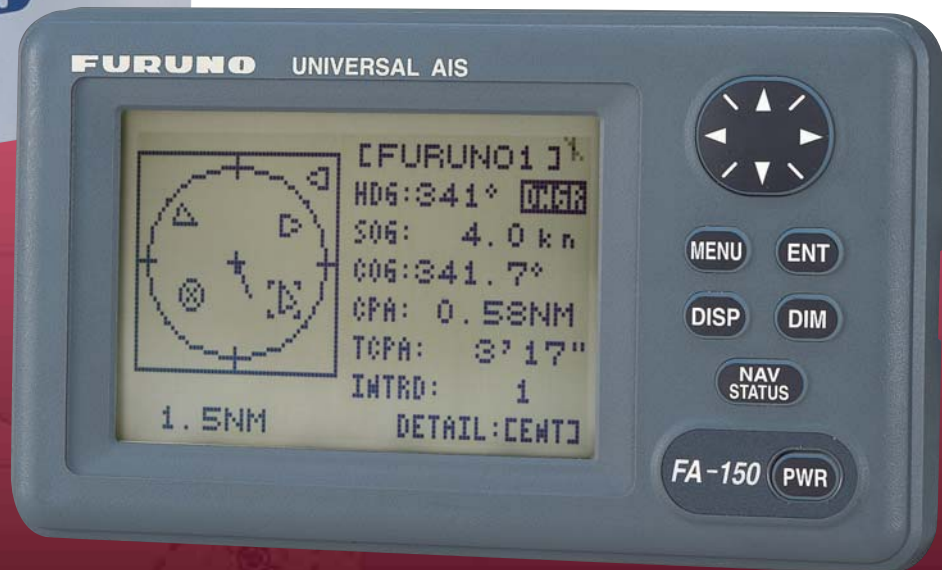

Model:
FA-150

A Class-A Universal Automatic Identification System (AIS) transponder, the FA-150 is designed to improve navigation safety by observing other AIS equipped ships. The FA-150 complies with relevant international regulations and standards (e.g., IMO, ITU-R, IEC) as well as national class requirements.

The FA-150 offers real-time information exchange of your own ships data and other AIS-equipped ships or coastal stations within VHF coverage. Information that is exchanged includes static, dynamic, voyage related data, as well as short safety-related messages.

The FA-150 consists of a GPS antenna, a transponder unit, a display unit and other associated equipment. The internal GPS receiver provides UTC reference for system

synchronization. It also gives position, COG and SOG if no external positioning equipment is connected. There are two types of configurations for the antenna unit: GPS and VHF combined and separate antennas. Both types of GPS antennas feature a special interference shield that allows superior performance when they are in an area of influence by equipment such as radar and satellite phones. An exceptionally compact GPS antenna is also available in the separate configuration.

The FA-150 can be interfaced with Radar and ECDIS, allowing AIS information to be displayed on them.

No additional interface units are required for connection to the FURUNO radar or ECDIS. Use of the WAGO connectors simplifies installation and connection.



FA-150

- ▶ Compact 4.5" silver bright display
- ▶ Full compliance with international regulations and standards
 - IMO MSC.74(69) Annex 3 • ITU-R M.1371 • IEC 60993-2
 - IEC 60945 • MTSA 2002 - U.S. AIS Requirements
- ▶ Integrates with Radar, ECDIS and Electronic Chart System
- ▶ Easy to operate
- ▶ Optional PC software
- ▶ Provides real-time AIS info for collision avoidance



Combined antenna



Separate GPS antennas

NAME	RNG (NM)	BRG(°)
*"SART"	0.81	242.5
FURUNO1	0.97	119.5
FURUNO3	1.12	55.9
FURUNO4	1.15	314.3
FURUNO2	2.02	45.3

Target list

HDG: 341°	DWGR
SOG: 4.0 kn	
COG: 341.7°	
CPA: 0.58NM	
TCPA: 3°17"	
INTRO: 1	
DETAIL:CENTJ	

Plotter

EPFS	18/NOV 02:29:19
L/L	18/NOV 02:29:19
SOG	18/NOV 02:29:19
COG	18/NOV 02:29:19
HDG	18/NOV 02:29:19
ROT	18/NOV 02:29:23

Alarm status

18/NOV/2009 02:28:57
LAT: 34°43.5000°N
LOX: 135°21.0000°E
SOG: 10.0 kn EXT GPS
COG: 155.4° HDG: 155°
ROT: R 12.9°/min
PA: H PAIM:USED

Own dynamic data

MMSI	: 100000000
NAME	: FURUNO
CALL SIGN:	
IMO NO.	: 000000000

Own static data

The AIS performance for safe navigation

AIS enhances detection of other ships and Aids to Navigation on radar and ECDIS units.

- ▶ AIS targets are visible even if they are behind large ships, islands or other landmasses
- ▶ AIS targets are not obscured by sea clutter and rain clutter
- ▶ ROT display at tip of COG/SOG vector allows navigators to predict course changes of other vessels



AIS COG/SOG vector changes its length with speed and a ROT mark is viewable at the COG/SOG vector tip when a target ship is equipped with a FURUNO satellite compass SC-50/110 or other compatible equipment.

ECDIS
Electronic Chart Display and Information System

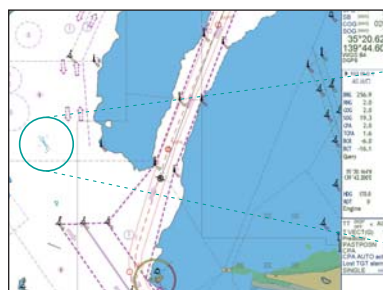

COG/SOG vector

ROT mark

RADAR



PC software

Optional PC software is available to facilitate comprehensive observation of AIS information. With this software application, chart overlay*, target information and targets list can be displayed on one display. *Requires chart data

AIS features include:

- ▶ Provides real-time AIS information for collision avoidance
- ▶ A means for coastal stations to obtain information about a ship and its cargo
- ▶ VTS tool, i.e., ship-to-shore traffic management

Information to be exchanged

- ▶ **Static Data**
 - MMSI (Maritime Mobile Service Identity)
 - IMO number (Where available)
 - Call sign & name
 - Length and beam
 - Type of ship
 - Location of position-fixing antenna on the ship
- ▶ **Dynamic data**
 - Ship's position with accuracy indication and integrity status
 - Coordinated universal time (UTC)
 - Course over ground (COG)
 - Speed over ground (SOG)
 - Heading
 - Navigation status (manual input)
 - Rate of turn (where available)
 - Update rates Dependent on speed and course alternation (2 s – 3 min)
- ▶ **Voyage related data**
 - Ship's draft
 - Hazardous cargo (type)
 - Destination and ETA (at masters discretion)
- ▶ **Short safety-related messages**
 - Free messages

Implementation schedule

(MSC.73 adopted on 5 December 2001 and Amendments adopted on 13 December 2002 by the Conference of Contracting Governments to the SOLAS 1974)

New build	All ships of ≥ 300 GT on international voyages	
	Cargo ships ≥ 500 GT not on international voyages	
	Passenger ships irrespective of size on all voyages	
Ships not on international voyages constructed before 1 July 2002	Passenger ships	Before 1 July 2008
	Ships, other than passenger ≥ 500 GT	

NOTE: All vessels in U.S. waters - Complies with MTSA 2002 (Maritime Transportation Security Act) U.S. AIS Requirements

SPECIFICATIONS

PRODUCT NAME

U-AIS Transponder

GENERAL

Standards

IMO A.694(17), IMO MSC.74(69) Annex 3,
IEC 61993-2, ITU-R M.1371-3, ITU-R M.825-3(DSC)
CCNR Test Standard for Inland AIS

Ship reporting capacity

2250 reports per minute, 4500 reports per minute on two channels

TRANSPONDER UNIT

TX/RX Frequency 156.025 MHz to 162.025 MHz
RX1: Default CH87B (161.975 MHz)
RX2: Default CH88B (162.025 MHz)
Output Power 1 W/ 12.5 W selectable
DSC Receiver CH70 fixed, 156.525 MHz, G2B, 1200 bps
Bandwidth 25 kHz/ 12.5 kHz

DISPLAY UNIT

Screen Size 4.5" monochrome LCD
Effective Viewing Area 95 (H) x 60 (V) mm
Pixel Number 120 (H) x 64 (V)

GPS RECEIVER

Receiving Channels 12 channels parallel, 12 satellites tracking
Rx Frequency/Rx Code 1575.42 MHz, C/A code
Position Fixing System All in view, 8-state Kalman filter
Position Accuracy 10 m (HDOP ≤ 4)

INTERFACE

COM 1 - 4* IEC 61162-1/61162-2
Input: VSD, SSD, ABM, BBM, ACA, ACK, AIR, DTM, GBS, GGA, GLL, GNS, HDT, LRF, LRI, OSD, RMC, ROT, VBW VTG PIWVVD, PIWVSSD, PIWVWSD
Output: VDM, VDO, ABK, ACA, ALR, TXT, LR1, LR2, LR3, LRF, LRI

*Note: COM 4 also functions as SENSOR input

SENSOR (input) IEC 61162-1/61162-2

COM 4 - 6

Input: DTM, GNS, GLL, GGA, RMC, VBW, VTG, OSD, HDT, GBS, ROT
AD-10 AD-10 format (FURUNO gyro format)

External Beacon RS-232C

PC RS-232C

Alarm Output 10/100 Base-T Ethernet (Option)

Contact closure

POWER SUPPLY

Transponder Unit 12-24 VDC: 7-3.5 A
Display Unit 12-24 VDC: 0.3-0.15 A
AC/DC Power Supply Unit PR-240 (option): 100/110/200/220 VAC, 1 Ø, 50/60 Hz

ENVIRONMENT

Temperature
GPS Antenna Unit -25°C to +70°C
Other Units -15°C to +55°C

Waterproofing (IEC 60529)
Antenna Unit IPX6

Vibration (IEC 60945 ed.4)

EQUIPMENT LIST

Standard

1. Transponder Unit FA-1501 1 unit
2. Display Unit FA-1502 1 unit
3. GPS Antenna Unit GSC-001-E, GPA-017S-E or GPS/VHF Combined Antenna Unit GVA-100 with Distribution Box DB-1 1 unit
4. Installation Materials 1 set

Option

1. VHF Antenna Unit 150M-W2VN with bracket
2. Antenna Cable Kit
 For GPS/VHF Combined Antenna GVA-100
 OP24-00300: 30 m, OP24-00310: 50 m
 For GSC-001 and GPA-017S
 TNC-PS-3D-15: 15 m, CP-20-02700: 30 m, CP-20-02710: 50 m
3. Antenna Base
 CP20-01111: Pipe mount, No. 13-QA310: Offset bracket, No. 13-QA330: Deck mount, No. 13-RC5160: Handrail mount
4. Cable between Display and Transponder Unit
 MJ-A10SPF0012-050/100/250/500/1000: 5/10/25/50/100 m
5. Flush Mount Kit OP20-29: F type, OP20-17: S type
6. Pilot Plug OP24-3
7. Software for PC
8. Power Supply Unit PR-240
9. LAN Interface for PC

Note: IMO requires that the AIS operate on ship's mains (115/230 VAC) and alternative power source, then a PR-240 is required. Check with your authorities for alternative power as it can be an emergency source (AC generator) or reserve source (batteries).

INTERCONNECTION DIAGRAM

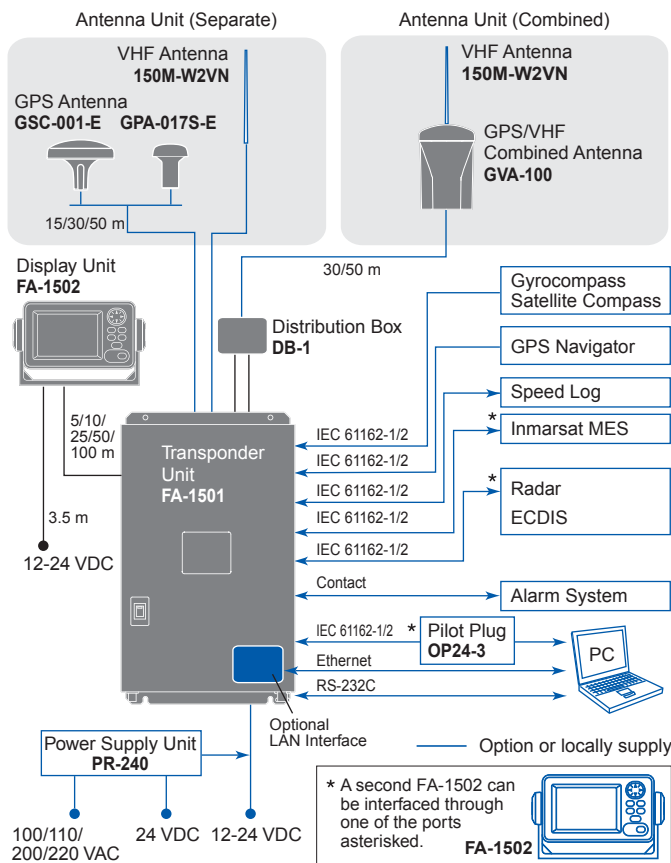

Transponder Unit

FA-1501 7.3 kg, 16.1 lb

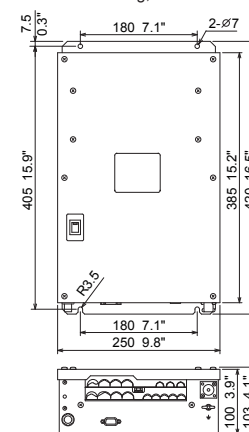

Display Unit

FA-1502 0.6 kg, 1.3 lb

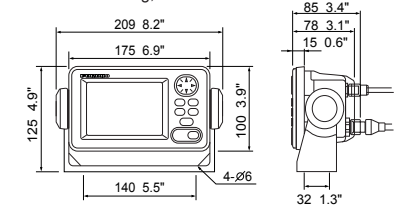

GPS Antenna

GSC-001-E 0.5 kg, 1.1 lb

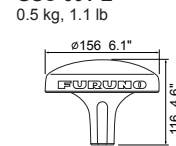

GPA-017S-E 0.15 kg, 0.3 lb

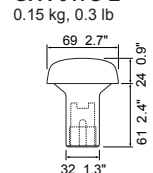

GPS/VHF Combined Antenna

GVA-100 3.3 kg, 7.3 lb

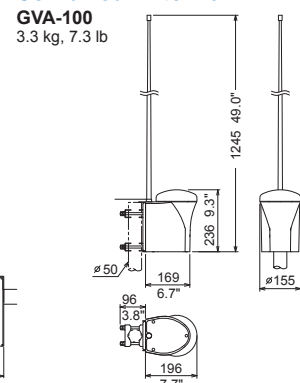

Distribution Box

DB-1 0.9 kg, 2.0 lb

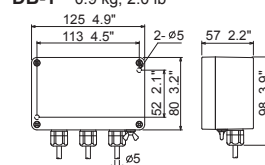

Pilot Plug (Option)

OP24-3 0.6 kg, 1.3 lb

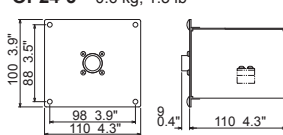

All brand and product names are registered trademarks, trademarks or service marks of their respective holders.

SPECIFICATIONS SUBJECT TO CHANGE WITHOUT NOTICE

FURUNO ELECTRIC CO., LTD.
Nishinomiya, Hyogo, Japan
www.furuno.com

FURUNO U.S.A., INC.
Camas, Washington, U.S.A.
www.furunousa.com

FURUNO (UK) LIMITED
Havant, Hampshire, U.K.
www.furuno.co.uk

FURUNO NORGE A/S
Ålesund, Norway
www.furuno.no

FURUNO DANMARK A/S
Hvidovre, Denmark
www.furuno.dk

FURUNO SVERIGE AB
Västra Frölunda, Sweden
www.furuno.se

FURUNO FINLAND OY
Espoo, Finland
www.furuno.fi

FURUNO POLSKA Sp. z o.o.
Gdynia, Poland
www.furuno.pl

FURUNO DEUTSCHLAND GmbH
Rellingen, Germany
www.furuno.de

FURUNO FRANCE S.A.S.
Bordeaux-Mérignac, France
www.furuno.fr

FURUNO ESPAÑA S.A.
Madrid, Spain
www.furuno.es

FURUNO ITALIA S.r.l.
Genoa, Italy

FURUNO HELLAS S.A.
Glyfada, Greece
www.furuno.gr

FURUNO (CYPRUS) LTD
Limassol, Cyprus
www.furuno.com.cy

FURUNO EURUS LLC
St. Petersburg, Russian Federation
www.furuno.ru

FURUNO SHANGHAI CO., LTD.
Shanghai, China
www.furuno.com/cn

FURUNO KOREA CO., LTD.
Busan, Korea

RICO (PTE) LTD
Singapore
www.rico.com.sg

14075SK Printed in Japan
Catalogue No. N-864g